

**The Enclosure & Instrument  
Case Designer & Manufacturer**

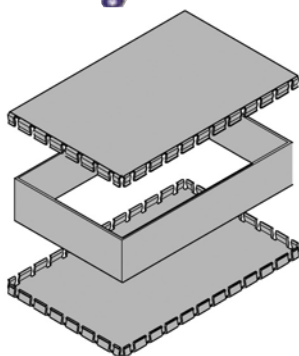

# RFI/EMI Metal Screening Enclosures

carefully manufactured by:

## PERANCEA LIMITED

Unit 36, Silicon Business Centre, 28 Wadsworth Road, Perivale Greenford, UB6 7JZ, England

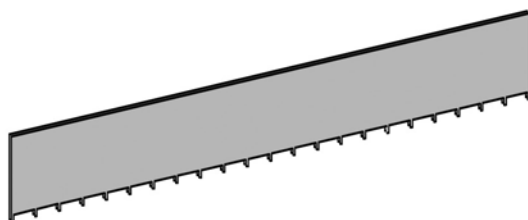

Tel: +44 (0) 20 8365 2520  
Email: [sales@perancea.com](mailto:sales@perancea.com)

Fax: +44 (0) 20 8566 7217  
Website: [www.perancea.com](http://www.perancea.com)

In line with our policy of continuous improvement, we reserve the right to make design or product alterations without prior notice.

# Perancea RFI/EMI Metal Screening Enclosures

Our RFI/EMI Screening Enclosures are a cost-effective and efficient means of specific board level shielding. As well as screening complete circuits and modules, they can be readily used to screen individual components or circuits from other sensitive areas within a circuit.

Four standard Perancea styles provide a choice between PCB mounting for full or partial circuit board screening, or Can or Open Frame styles for enclosing a complete circuit. Three styles feature removable fingered lids that combine the advantages of access with optimum attenuation. PCB mounting Can versions provide a lower cost option where access to components and/or circuitry is not required. Screening strips, for creating partitioning within an enclosure to segregate sensitive areas of circuitry and/or components, can be readily supplied loose or fitted to specification, and where required, complex labyrinths can be achieved.

With Perancea's advanced technology, we can produce, without tooling charges, virtually any 'custom' size to meet exacting customer specifications, thus enabling prototypes and low volumes to be economically produced. Additional RFI/EMI Screening Enclosure features such as holes, cut-outs, mounting brackets and more, are easily incorporated during manufacture to accommodate specific product design requirements.

Helpful custom advice on what we can achieve for you is provided on page 8 of this publication. Moreover, why not call us today and find out exactly what we can do to help you optimise your designs and costs!

## Contents

### PCB Frames & Fingered Lids: Page 3

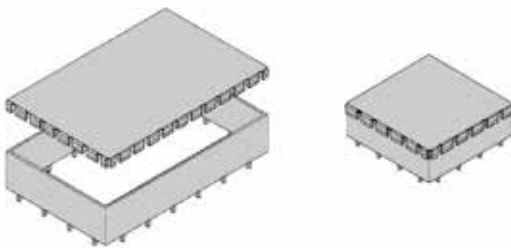

### Frames & Fingered Lids: Page 4

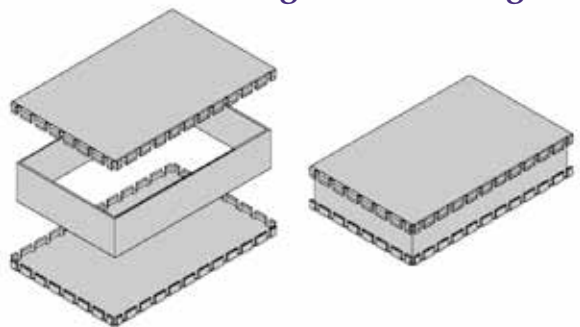

### Cans & Fingered Lids: Page 5

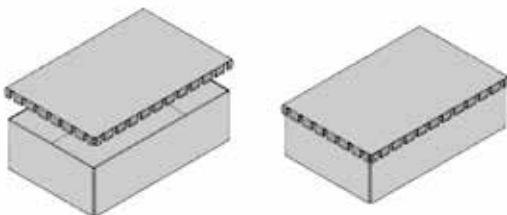

### PCB Mounting Cans: Page 6

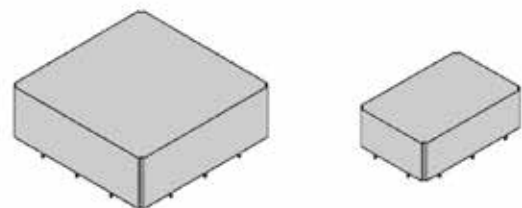

### Screening Strips & Locking Pins: Page 7

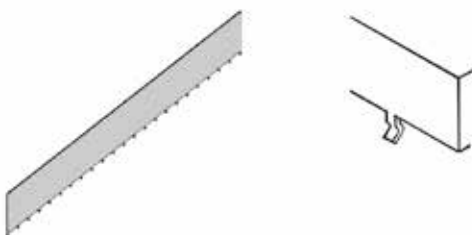

### Customisation Options: Page 8

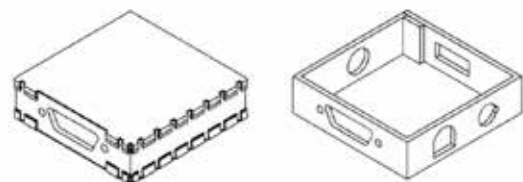

Tel: +44 (0) 20 8365 2520  
Email: [sales@perancea.com](mailto:sales@perancea.com)

**PERANCEA**

Fax: +44 (0) 20 8566 7217  
Website: [www.perancea.com](http://www.perancea.com)

# PFL Series: PCB Frames & Fingereed Lids

Standard & custom PCB mounting enclosures provide individuality and functionality for electronics designs. They are ideal for board level screening where high RFI/EMI attenuation and accessibility are essential.

## π Removable Fingereed Lids

provide easy access and excellent attenuation

## π PCB Mounting Pins

bright acid tinned for high solderability

## π Locking Pins (optional)

enable positive placement and retention – see page 7  
particularly ideal for reflow soldering applications

## π Internal Dividers (optional)

provide discrete screening within the frame – see page 8

## π Custom Sizes

our enclosures can be manufactured without tooling charges  
enabling viable prototype and low volume production

## π Additional Features

holes, brackets, cut-outs, lid captivation and more, can be readily incorporated during manufacture – see page 8

## π Alternative Materials & Finishes

copper, brass, tinfoil, nickel, nickel plate

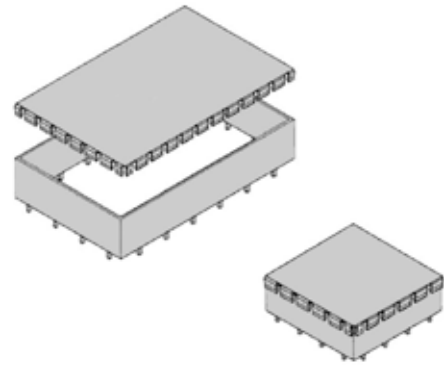

## Specification

<b>Material:</b>	Bright Mild Steel BS EN 10130 DC01
<b>Frames:</b>	20swg (0.914mm)
<b>Lids:</b>	23swg (0.6mm)
<b>Finish:</b>	Bright Acid Tin Good Commercial Grade
<b>Surface Resistivity:</b>	20 x 10 <sup>-6</sup> Ω per square
<b>Conductivity:</b>	5 x 10 <sup>4</sup> S (mho)
<b>Tolerance:</b>	+/-0.25mm (general) +/-0.10mm (PCB pin pitch)
<b>Pin Size:</b>	1mm x 2.25mm

## STOCK SIZES - Internal & Overall Dimensions in mm

Part No.	Dim. A	Dim. B	Dim. C	Nominal Overall Size Including Lid (excluding pins)	Number of Pins	Pin Pitch
PFL1T	20	20	10	25 x 25 x 11	4	C/L
PFL11T	25	25	10	30 x 30 x 11	4	C/L
PFL5T	30	30	15	35 x 35 x 16	8	10.5
PFL13T	40	40	10	45 x 45 x 11	8	20
PFL12T	40	40	15	45 x 45 x 16	8	20
PFL14T	50	25	10	55 x 30 x 11	10	10.5
PFL2T	50	25	15	55 x 30 x 16	10	10.5
PFL6T	50	50	15	55 x 55 x 16	8	20
PFL9T	75	50	15	80 x 55 x 16	12	20
PFL3T	75	50	25	80 x 55 x 26	12	20
PFL15T	75	50	30	80 x 55 x 31	12	20
PFL16T	75	75	10	80 x 80 x 11	16	20
PFL7T	75	75	25	80 x 80 x 26	16	20
PFL17T	100	50	15	105 x 55 x 16	12	20
PFL4T	100	50	25	105 x 55 x 26	12	20
PFL8T	125	75	25	130 x 80 x 26	20	20
PFL18T	125	75	35	130 x 80 x 36	20	20
PFL10T	160	100	35	165 x 105 x 36	24	20

**Note: A4 dimensioned drawings for all parts available on request.**

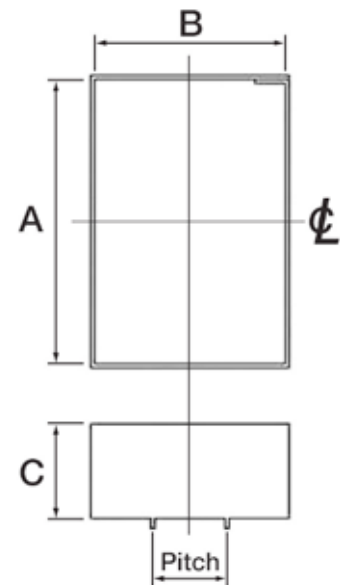

Tel: +44 (0) 20 8365 2520  
Email: sales@perancea.com

**PERANCEA**

Fax: +44 (0) 20 8566 7217  
Website: www.perancea.com

# FFL Series: Frames & Fingereid Lids

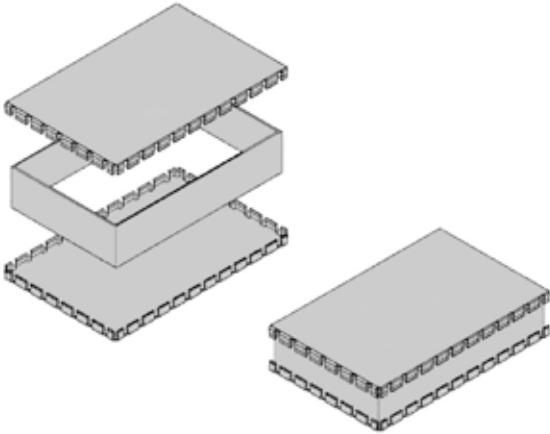

## Specification

<b>Material:</b>	Bright Mild Steel BS EN 10130 DC01
<b>Frames:</b>	20swg (0.914mm)
<b>Lids:</b>	23swg (0.6mm)
<b>Finish:</b>	Bright Acid Tin Good Commercial Grade
<b>Surface Resistivity:</b>	20 x 10 <sup>-6</sup> Ω per square
<b>Conductivity:</b>	5 x 10 <sup>4</sup> S (mho)
<b>Tolerance:</b>	+/-0.25mm (general)

Open frame RFI/EMI housings with removable lids in both standard and custom versions, are specifically designed for total board screening, providing excellent attenuation and access to both sides of the PCB.

### π Removable Fingereid Lids

provide easy access and excellent attenuation

### π Lid Fingereid Clearance (*optional*)

selective fingers can be omitted for clearance around components mounted through the frame wall

### π PCB Locations (*optional*)

lanings or brackets can be specified to act as guides or supports – see page 8

### π Internal Dividers (*optional*)

provide discrete screening within the frame – see page 8

### π Custom Sizes

our enclosures can be manufactured without tooling charges enabling viable prototype and low volume production

### π Additional Features

holes, brackets, cut-outs, lid captivation and more, can be readily incorporated during manufacture – see page 8

### π Alternative Materials & Finishes

copper, brass, tinplate, nickel, nickel plate

## STOCK SIZES - Internal & Overall Dimensions in mm

Part No.	Dimension A	Dimension B	Dimension C	Nominal Overall Size Including Lid
FFL6T	20	20	10	25 x 25 x 12
FFL7T	30	30	15	35 x 35 x 17
FFL1T	50	50	15	55 x 55 x 17
FFL5T	75	50	15	80 x 55 x 17
FFL8T	75	50	25	80 x 55 x 27
FFL9T	75	75	25	80 x 80 x 27
FFL2T	100	50	25	105 x 55 x 27
FFL10T	125	75	25	130 x 80 x 27
FFL3T	160	100	35	165 x 105 x 37
FFL4T	220	100	50	225 x 105 x 52

*Note: A4 dimensioned drawings for all parts available on request.*



Tel: +44 (0) 20 8365 2520  
Email: sales@perancea.com

**PERANCEA**

Fax: +44 (0) 20 8566 7217  
Website: www.perancea.com

# CFL Series: Cans & Fingered Lids

Perancea Standard & custom RFI/EMI Cans provide excellent attenuation and accessibility where the complete board or circuit screening is required.

- π Removable Fingered Lids**  
provide easy access and excellent attenuation
- π Lid Fingering Clearance**  
selective fingers can be omitted for clearance around components mounted through the frame wall
- π Component/PCB Locations (optional)**  
lancings or brackets can be specified to act as guides or supports – see page 8
- π Butt Jointed Corners**  
the bright acid tin finish enables corners to be readily soldered for increased screening
- π Internal Dividers (optional)**  
provide discrete screening within the can – see page 8
- π Custom Sizes**  
our enclosures can be manufactured without tooling charges, enabling viable prototype and low volume production
- π Additional Features**  
holes, brackets, cut-outs, lid captivation and more, can be readily incorporated during manufacture – see page 8
- π Alternative Materials & Finishes**  
copper, brass, tinplate, nickel, nickel plate

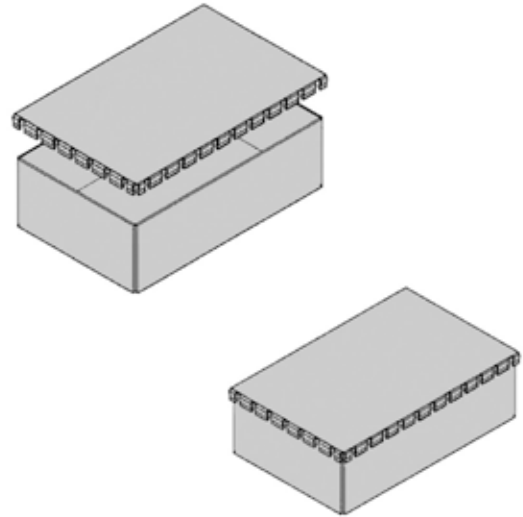

## Specification

<b>Material:</b>	Bright Mild Steel BS EN 10130 DC01
<b>Frames:</b>	20swg (0.914mm)
<b>Lids:</b>	23swg (0.6mm)
<b>Finish:</b>	Bright Acid Tin Good Commercial Grade
<b>Surface Resistivity:</b>	$20 \times 10^{-6} \Omega$ per square
<b>Conductivity:</b>	$5 \times 10^4 S$ (mho)
<b>Tolerance:</b>	+/-0.25mm (general)

## STOCK SIZES - Internal & Overall Dimensions in mm

Part No.	Dimension A	Dimension B	Dimension C	Nominal Overall Size Including Lid
CFL5T	20	20	10	25 x 25 x 12
CFL6T	30	30	15	35 x 35 x 17
CFL9T	30	30	30	35 x 35 x 32
CFL7T	50	25	15	55 x 30 x 17
CFL1T	50	50	15	55 x 55 x 17
CFL2T	75	50	25	80 x 55 x 27
CFL8T	75	75	25	80 x 80 x 27
CFL3T	100	50	35	105 x 55 x 37
CFL4T	160	100	50	165 x 105 x 52

**Note: A4 dimensioned drawings for all parts available on request.**

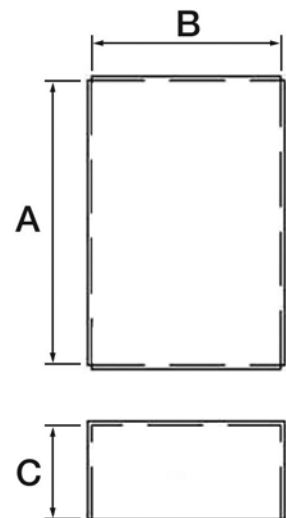

Tel: +44 (0) 20 8365 2520  
Email: sales@perancea.com

**PERANCEA**

Fax: +44 (0) 20 8566 7217  
Website: www.perancea.com

# PCMC Series: PCB Mounting Cans

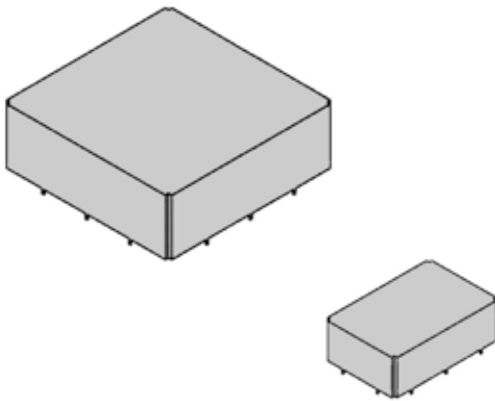

## Specification

<b>Material/Finish:</b>	Tinplate to BS EN 10202:2001
<b>Thickness:</b>	0.49mm
<b>Surface Resistivity:</b>	$20 \times 10^{-6} \Omega$ per square
<b>Conductivity:</b>	$5 \times 10^4 S$ (mho)
<b>Tolerance:</b>	+/-0.25mm (general) +/-0.10mm (PCB pin pitch)
<b>Pin Size:</b>	1mm x 2.25mm

Low cost, single piece, Perancea PCB mounting Cans provide excellent attenuation for applications where board level RFI/EMI screening is required. They are readily available in standard or custom options.

### π PCB Mounting Pins

tinplate finish for solderability

### π Locking Pins (optional)

enable positive placement and retention – see page 7 particularly ideal for reflow soldering applications

### π Butt Jointed Corners

the tinplate finish enables corners to be easily soldered for increased screening

### π Custom Sizes

our enclosures can be manufactured without tooling charges, enabling viable prototype and low volume production

### π Additional Features

holes, brackets, cut-outs, lid captivation and more, can be readily incorporated during manufacture – see page 8

### π Alternative Materials

copper, brass, steel, nickel

### π Alternative Finishes

bright acid tin, nickel plate

## STOCK SIZES - Internal & Overall Dimensions in mm

Part No.	Dim. A	Dim. B	Dim. C	Nominal Overall Size	Number of Pins	Pin Pitch
PCMC1	20	20	15	21 x 21 x 16	4	C/L
PCMC2	25	25	15	26 x 26 x 16	8	10.5
PCMC3	30	25	20	31 x 26 x 21	8	10.5
PCMC4	30	30	15	31 x 31 x 16	8	10.5
PCMC5	40	30	15	41 x 31 x 16	10	10.5
PCMC6	40	35	20	41 x 36 x 21	12	10.5
PCMC7	40	40	15	41 x 41 x 16	8	20
PCMC8	50	50	15	51 x 51 x 16	8	20
PCMC9	60	40	20	61 x 41 x 21	10	20
PCMC10	70	50	25	71 x 51 x 26	10	20
PCMC11	75	75	25	76 x 76 x 26	12	20
PCMC12	100	50	25	101 x 51 x 26	12	20

Note: A4 dimensioned drawings for all parts available on request.

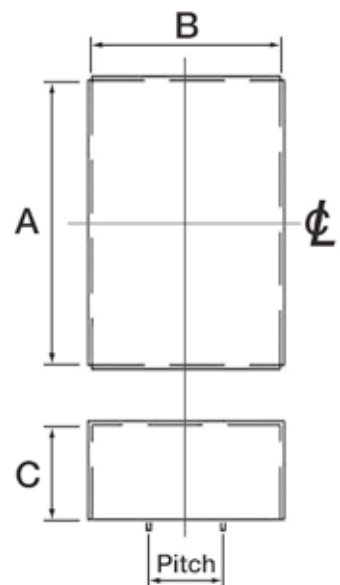

Tel: +44 (0) 20 8365 2520  
Email: sales@perancea.com

**PERANCEA**

Fax: +44 (0) 20 8566 7217  
Website: www.perancea.com



# SS Series: Screening Strips

An ideal solution for segregating sensitive components or circuitry, to eliminate and/or minimise interference between different circuit parts.

- π Range Screening Strip Heights**  
to suit standard enclosures
- π Adaptability**  
easily cut to length, bent and soldered
- π Custom Fit**  
can be readily supplied pre-fitted by either spot welding in position or by tab & slot location
- π Labyrinths**  
multi-segmented areas optimise discrete screening
- π Custom Sizes**  
no tooling charges enable viable prototyping as well as low volume production
- π Alternative Materials & Finishes**  
copper, brass, steel, nickel/tin, nickel, bright acid tin

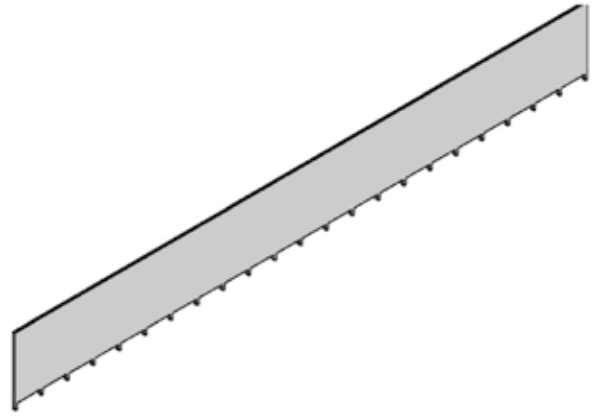

## Specification

- Material/Finish:** Tinplate to BS EN 10202:2001
- Thickness:** 0.49mm
- Surface Resistivity:**  $20 \times 10^{-6} \Omega$  per square
- Conductivity:**  $5 \times 10^4 S$  (mho)
- Tolerance:**  $\pm 0.25$ mm (general)  
 $\pm 0.10$ mm (PCB pin pitch)
- Pin Size:** 1mm x 2.25mm

## STOCK SIZES - Internal & Overall Dimensions in mm

Part No.	Dimension A	Dimension B	Number of Pins	Pin Pitch
SS232/10	232	10	23	10.5
SS232/15	232	15	23	10.5
SS232/20	232	20	23	10.5
SS232/25	232	25	23	10.5
SS232/35	232	35	23	10.5
SS232/50	232	50	23	10.5

**Note: A4 dimensioned drawings for all parts available on request.**

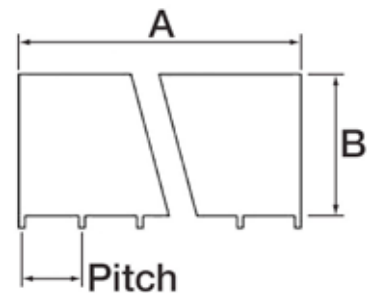

## Perancea Locking Pins

This special Locking Pin is designed to retain an enclosure securely in place on the PCB during reflow soldering, ensuring full contact is maintained between the frame or edge can and the solder paste. An extremely reliable solder joint with optimum screening is therefore achieved.

The pin is designed such that only minimal force is required to place an enclosure on the board, making it ideally suited to pick & place board assembly applications. This unique concept for PCB assembly also has major hand-soldering advantages, as operators are assured that the enclosure is fully in place during soldering, providing increased reliability and also the potential for increased productivity.

This new Locking Pin feature is available as standard on all sizes of Perancea PCB Mounting Frames and Cans.

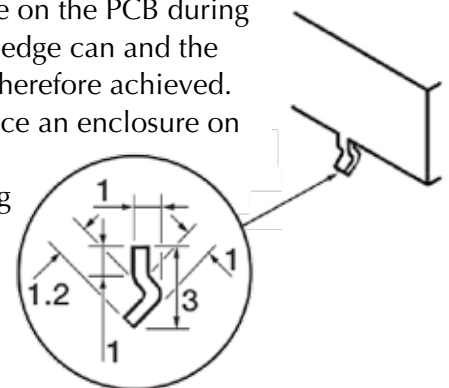

Tel: +44 (0) 20 8365 2520  
Email: sales@perancea.com

**PERANCEA**

Fax: +44 (0) 20 8566 7217  
Website: www.perancea.com

# Custom Options

Design your own enclosures choosing from our standard styles:

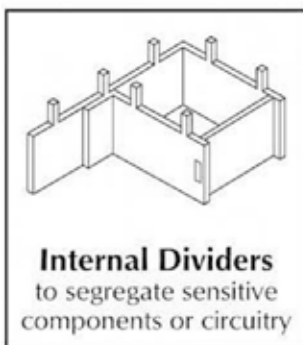
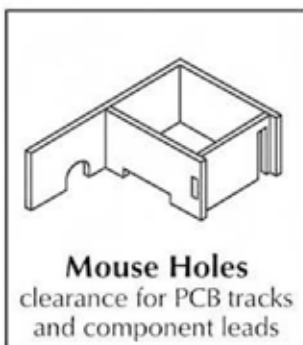
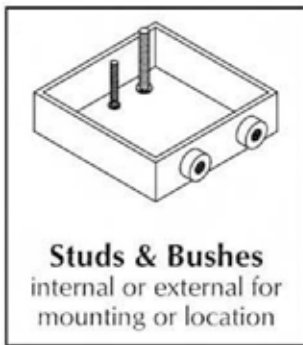
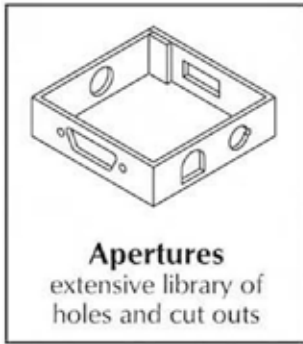
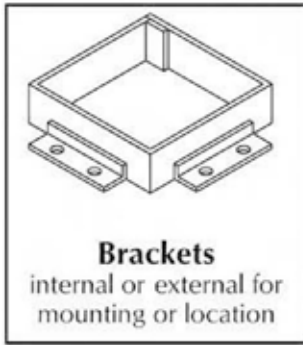

- STYLE:** Specify CFL, FFL, PFL or PCMC versions.
- DIMENSIONS:** Specify length, width and height as internal. Other dimensions from centre lines.
- MATERIAL:** Options include steel, tin plate, copper, brass, nickel. Specify thickness or gauge.
- FINISH:** Nickel Plate, Zinc Plate, Bright Acid Tin: Good Commercial Grade: BS1872: 1984 Service Condition 2 or Def Stan 03-8 Iss1.
- MOUNTING:**  
**Brackets:** Specify size & position  
**Bushes:** Specify thread & position  
**Studs:** Specify thread, length & position
- APERTURES:** Holes or cut-outs. Specify style, size & position. Most component sizes available as standard.
- CORNER OVERLAP:** For frames, specify corner. Minimum is 5mm. External option available.
- INTERNAL DIVIDERS:** Specify as required. Can be supplied loose, spot welded or with tabs, to mate with slots in wall. Multi-compartments can be easily achieved by a labyrinth of dividers.
- PCB LOCATIONS:** Lancings can be horizontal or vertical for PCB supports, or staggered to act as guides. (See diagram.)
- PCB PINS:** Specify size & position. Min size: 0.75 x 1 mm.
- EARTH TERMINALS:** Specify type, size & position. Options: push-on/ solder tags; studs; earth symbol.
- LID FINGERING:** Size & style are standard. Fingers can be omitted for clearance around through-wall components.
- MARKING:** Alphanumeric: 2mm impressed characters available as standard. Also earth symbol - specify position.
- MOUSE HOLES:** Walls & dividers can have small cut-outs on the edges to clear PCB tracks and/or component leads.
- LANCINGS:** For mounting component leads or location points.
- LOCKING PINS:** Locate & retain enclosures on PCB for soldering (See page 7.)
- LID CAPTIVATION:** Locking devices for additional lid security.
- Solder Anti-Migration System - prevents solder creepage**

