

NEW



Exceptional Performance

## Dual Ultra

High performance, flexibility and controlled speed





## Dual Ultra

# High performance, flexibility and controlled speed

The Dual Ultra has been engineered to provide the best 2-component battery dispensing performance available today. Designed for the professional and specialist trade user across all industry sectors who demand a reliable and high performance dispensing tool.

### Delivering high material output in a precise and controlled manner.

The fully integrated application system features first-in-class cordless technology, powered by the latest 18V lithium-ion batteries and chargers utilizing the CoolPack battery technology from Bosch Professional batteries.

Dual Ultra provides the greatest flexibility; the twin rack drive platform ensures even high viscosity materials maintain their mixing ratio throughout the dispensing cycle. Interchangeable cartridge holding straps and plungers allow for quick and easy configuration - maximizing productivity in demanding applications. The ergonomic design provides the user with a perfectly well balanced tool, for best dispensing performance the finger-tip control features an overload shut-off and anti-drip mechanism preventing material discharge.

The electronics and software technology combined with intelligent force management ensures that users have complete control over the output speed of the dispenser.

### Dual Ultra includes 2-year warranty for dispenser, battery and charger.

#### Applications



Bonding



Repair



Sealing



Shimming



Model shown: ElectraFlow Dual Ultra VBE 400 MR  
Warranty: 2-year warranty for dispenser, battery and charger



# Dual Ultra

## High performance, flexibility and controlled speed

A tool platform that provides the greatest flexibility in dispensing across a range of 2-component platforms, including high viscosity materials.

# Dual Ultra

## Application System Overview

The Dual Ultra offers the compatibility with the following application systems.



### Bosch Professional battery and charger

Dual Ultra VBE 400 MR features first-in-class cordless technology powered by the latest 18V lithium-ion batteries and chargers utilizing the CoolPack battery technology from Bosch Professional batteries.



### CoolPack battery technology

Bosch Professional batteries heat dissipating housings improve product safety by preventing possible overheating, prolonging battery life and extending runtime.



### Interchangeable straps and plungers

Interchangeable cartridge holding straps and plungers allow for quick and easy configuration - maximizing productivity in demanding applications.



### Variable speed dial

Nine speed settings and a variable speed trigger give the user the control they need for a high quality finish.



### The C-System

Manufactured from high quality, chemical resistant plastics to meet stringent shelf-line stability and metering requirements for your formulated products. Suitable for the Dual Ultra 400mL volume and mixing ratios 1:1, 2:1, 4:1, 10:1 – combined with dedicated mixing tips.



### The F-System

Manufactured from high quality, chemical resistant plastics to meet stringent shelf-line stability and metering requirements for your formulated products. Suitable for the Dual Ultra 400mL volume and mixing ratios 1:1, 2:1, 4:1, 10:1 – combined with the Helix and Quadro mixing tips.

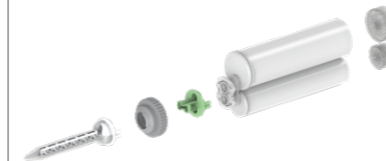

### The Blueline System

A solution provider for material with flow issues - ideal for high viscosity material that is difficult to dispense. No cross contamination thanks to specific interface design, available for 400mL cartridges with mixing ratio 2:1, 10:1 combined with T-mixer mixing tips.



### The Mixers

A wide range of mixers of the MIXPAC™ and QUADRO™ type for different applications with the 2-component Systems.



# A 2-component battery powered bead 400mL dispenser for cartridges.



## Specifications

- Weight: 3.8kg / 8.4lbs
- Frame Length: 203mm / 8.0in
- Maximum Thrust: 5.0kN
- Voltage: 18V
- Battery Capacity: 2.0Ah, 4.0Ah
- Battery Charge Time: 35min (2.0Ah), 45min (4.0Ah)
- Battery Type: Li-ion
- Handle Material: PC/ABS
- Frame Material: Steel /Aluminum
- Tool Component Approvals: IBS EN 62841, CE, REACH, RoHS
- Cartridge Capacity: 400mL (14oz)
- Cartridge Ratio: 1:1, 2:1, 4:1, 10:1
- Viscosity: Medium/High
- Standard Color: Grey/Black
- Customized versions on demand

## Dimensions

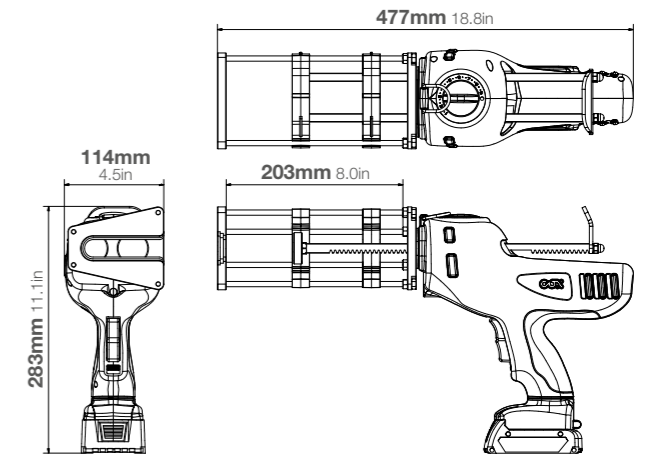

Fingertip control for optimal dispensing

2-component twin rack platform

Interchangeable holding straps and plungers

Variable 9-speed dial

## C-System

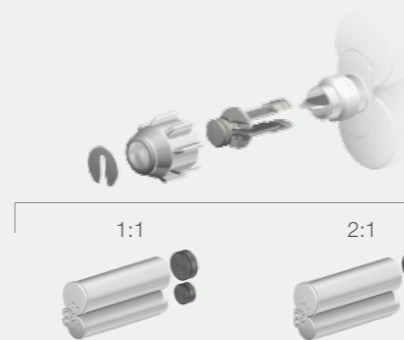

## F-System

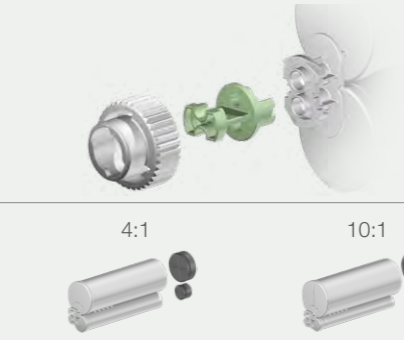

## Blueline

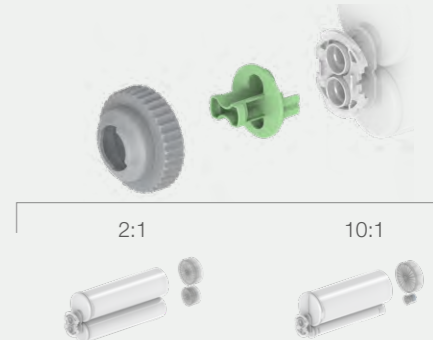

## Compatible plastic cartridges

	400mL 1:1		400mL 2:1		400mL 10:1	
	mm	inch	mm	inch	mm	inch
a	185.0	7.3	185.0	7.3	183.0	7.2
b	Ø45.0	Ø1.8	Ø47.0	Ø1.9	Ø65.0	Ø2.5
c			Ø33.0	Ø1.3	Ø20.0	Ø0.8

Model shown: Dual Ultra VBE 400 MR with 10:1 cartridge, plungers and straps

## Dual Ultra

High performance, flexibility and controlled speed



Solutions Customers Stick With

Adhesive Dispensing Ltd  
14 Clarke Road  
Milton Keynes  
Buckinghamshire  
MK1 1LG, UK

Tel: +44 (0) 1908 686660  
Fax: +44 (0) 1908 686836  
[info@adhesivedispensers.co.uk](mailto:info@adhesivedispensers.co.uk)  
[www.adhesivedispensing.co.uk](http://www.adhesivedispensing.co.uk)