

Techcon Systems TS6500CIM Automatic Techkit Mixer

User Guide
English



CONTENTS

	Page Number
1. Safety.....	3
2. Unpacking and Inspection.....	3
3. Description	4
4. Symbol Definitions.....	4
5. Emergency Stop.....	4
6. Specifications.....	5
7. Features and Function.....	6-10
7.1 Features.....	6-8
7.2 Operation Function	9-10
8. Setup and Operation.....	11-17
8.1 Voltage Selection and Fuse Replacement	11
8.2 Plastic Tray Installation.....	12
8.3 Spindle and Extension Installation.....	12-13
8.4 Turn on the Unit.....	13-14
8.5 Cartridge Kit Preparation.....	14
8.6 Loading the Cartridge Kit.....	15
8.7 Mix Cycle Program Setup.....	16
8.8 Start the Unit.....	16
8.9 Unloading the Cartridge Kit.....	16
8.10 Manual Mode.....	16-17
9. Speed Control.....	17
9.1 For Main Cylinder.....	17
9.2 For Injection Rod.....	17
10. Troubleshooting.....	18
11. Program Selection.....	19
12. Cycle Counter Reset.....	19
13. Cartridge Holder Installation.....	19-20
14. Maintenance	21
15. Warranty.....	21
16. Appendix	
16.1 Spare Parts List.....	22-24
16.2 Techkit Part Number Chart.....	25

1. SAFETY

Intended Use:

WARNING: Use of this equipment in ways other than those described in this User Guide may result in injury to persons or damage to property. Use this equipment only as described in this User Guide.

OK International cannot be responsible for injuries or damages resulting from unintended applications of its equipment. Unintended uses may result from taking the following actions:

- Making changes to equipment that has not been recommended in the User Guide
- Using incompatible or damaged replacement parts. Using unapproved accessories or auxiliary equipment

Safety Precautions:

- Do not operate this unit in excess of maximum ratings/settings
- Always wear appropriate personal protective clothing or apparel
- Care must be taken to prevent the ingress of corrosive or flammable fluid back into the Refer to Material Safety Data Sheet for proper handling and safety precautions
- Do not smoke or use open flame when flammable materials are being dispensed
- This equipment is for indoor use only.

2. UNPACKING AND INSPECTION:

Carefully open the crate and examine all items contained inside.

The following items should be included:

1. TS6500CIM Main Assembly – in the main compartment
2. Accessory parts – packaged in a box and stored in an accessory compartment, which include:

Description (Quantity)	Description (Quantity)
Cartridge Holder Assembly (1)	Air Filter (1)
Plunger Assembly (1)	Wrench holder (1)
Tool Holder (1)	User Guide (1)
Plunger Holder (1)	Air Hose (1)
Spare O-ring (5)	Fuse (1)
Spindle Assembly (1)	Power Cord (1)
Spindle Extension (1)	Screws (8)

3. DESCRIPTION

The TS6500CIM Series Automatic Techkit Mixer provides complete automatic mixing of two-component materials packaged in cartridge.

Equipped with a universal power supply, the TS6500 mixer is immediately usable anywhere in the world. The automatic fluid sensing device makes it very simple for the operator to install and setup all cartridge kit sizes. The user friendly firmware provides up to 10 programmable mixing sequences with storage for 10 profiles.



The TS6500CIM Series is available in five versions:

- TS6500CIM-6 for 2.5oz. (60ml), 6.0oz. (160ml) and 8.0oz. (220ml) Kit
- TS6500CIM-20 for 20oz. (550ml) Kit
- TS6500CIM-RS-6 for 6.0oz. (160ml) Kit with reduced motor speed (116 RPM)
- TS6500CIM-SMR-6 for 6.0oz. (160ml) Kit with steel mix rod
- TS6500CIM-SMR-20 for 20oz. (550ml) Kit with steel mix rod

The following conversion kits are also available for your conveniences:

- CK6500-6 Conversion kit for 2.5 (60ml), 6.0 (160ml) and 8.0 oz. (220ml) Kit
- CK6500-10 Conversion kit for 1/10 gal.(310ml) Kit
- CK6500-20 Conversion kit for 20 oz.(550ml) Kit

4. SYMBOL DEFINITIONS

Symbol	Definition
	Power On/Off
	Cycle Mode
	Set-Up

5. EMERGENCY STOP

In case of an emergency, the mixing operation can be stopped at any time by pressing the EMERGENCY STOP BUTTON, (Fig 2, 10). After the problems have been fixed, the machine can be restarted by pulling and turning the emergency button counter clockwise. The mix cycle will start from the beginning.

6. SPECIFICATIONS

Size	16.5" (420mm) X 16.8" (426mm) X 38.2" (970mm)
Weight	80lbs (36kg)
Input Voltage	120/230 VAC, 50/60 Hz
Rated Fuse	2A @ 120 VAC / 230 VAC
Motor Speed	139 RPM
Motor Torque	42 in-lb (4.7 Nm)
Indoor Use	Altitude up to 6,562ft (2,000m)
Operating Temperature	32°F to 122°F (0°C to 50°C)
Storage Temperature	-10°C to 60°C (14°F to 140°F)
Max. Relative Humidity	80% for temperature up to 87.8°F (31°C) Decreasing linearly to 50% relative humidity at 104°F (40°C)
Air Input	50 to 100 psi (3.5 – 6.9 bar)
Display	LCD 20 X 4 display segments

Figure 1.0 Outside Dimensions

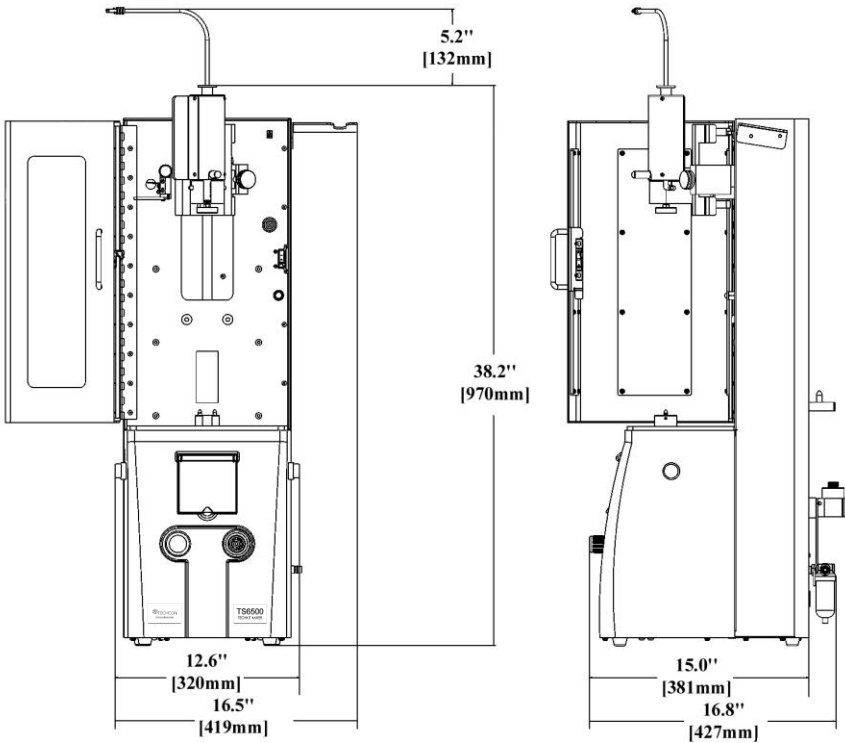

7. FEATURES AND FUNCTIONS

7.1 Features

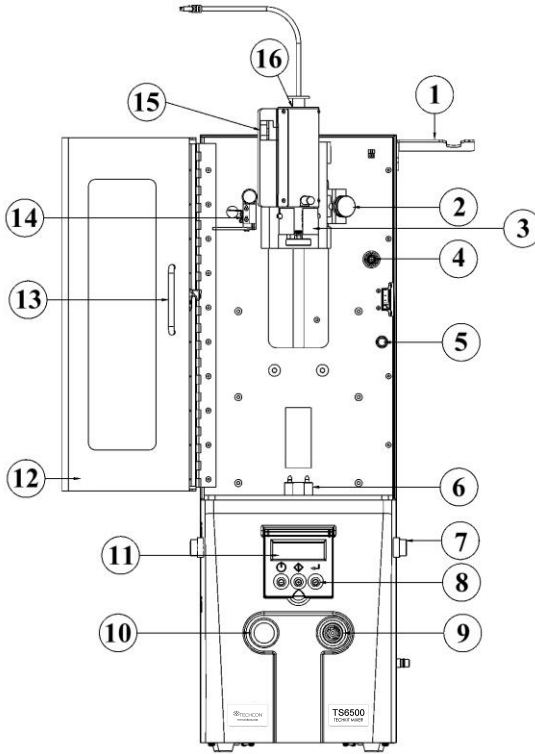

Figure 2.0 Front View

ITEM	DESCRIPTION	ITEM	DESCRIPTION
1	Plunger Bracket	9	Air Regulator
2	Cartridge Holder	10	E-Stop Button
3	Guide Block	11	LCD Display
4	Plunger Air Inlet	12	Safety Cover
5	Pressure Relief Valve	13	Handle
6	Drive Spindle with Injection Rod	14	Fluid Level Sensor
7	Start Buttons	15	Fluid Level Sensor Magnet
8	Control Buttons	16	Plunger

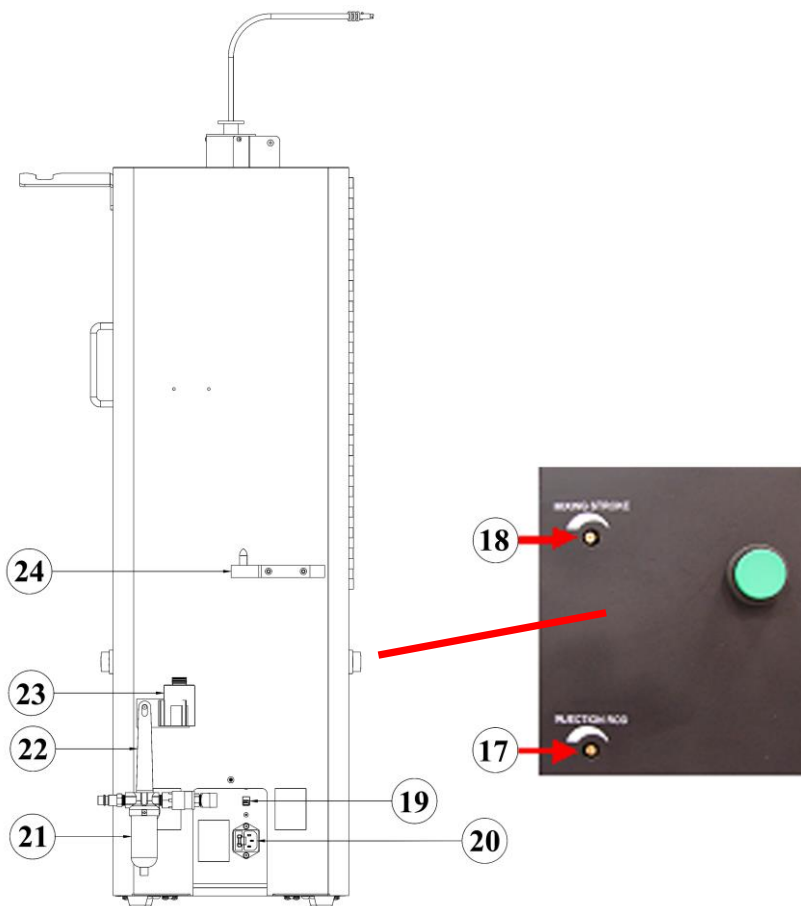

Figure 3.0 Back View

ITEM	DESCRIPTION	ITEM	DESCRIPTION
17	Flow Control, Injection Rod	21	Air Filter
18	Flow Control, Main Cylinder	22	Wrench
19	Voltage Select Switch	23	Accessories Bracket
20	Power Input Socket with Fuse box	24	Cartridge Holder Bracket

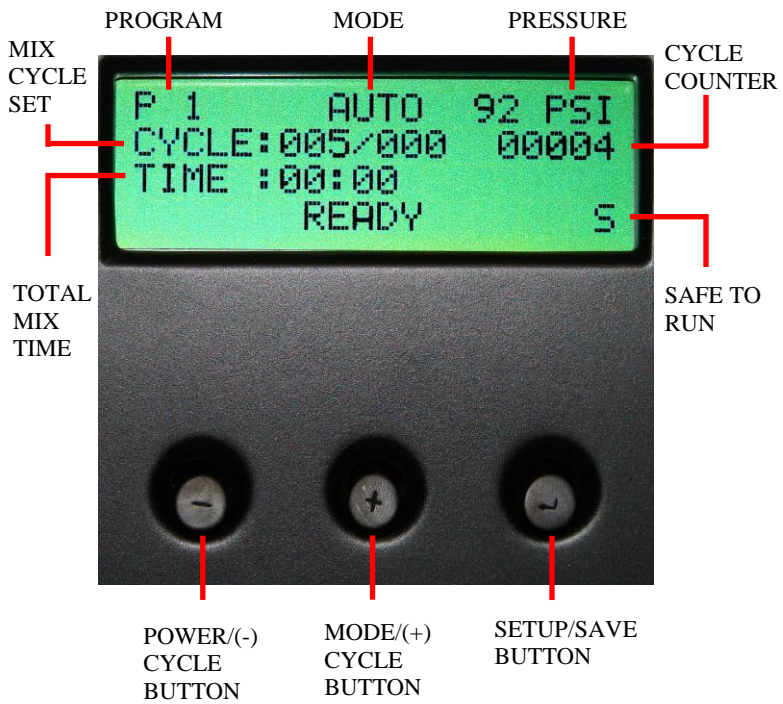

Figure 4.0 Buttons and Screen Identification



Figure 5.0 Setup Screen Identification

7.2 Operation Function

	DESCRIPTION	FUNCTION
1	Plunger Bracket	<ul style="list-style-type: none"> • Holds plunger assembly when not in use
2	Cartridge Holder	<ul style="list-style-type: none"> • Holds cartridge kit • Operates with the plunger assembly and guide block to drive the cartridge up and down for mixing
3	Guide Block	<ul style="list-style-type: none"> • Operates with the plunger assembly and cartridge holder to drive the cartridge up and down for mixing
4	Air Plunger Inlet	<ul style="list-style-type: none"> • Provides air to plunger
5	Pressure Relief valve	<ul style="list-style-type: none"> • Relief plunger pressure when door is opened
6	Drive Spindle with Injection Rod	<ul style="list-style-type: none"> • Rotates mix rods during mix cycle • Injects the hardener into the resin
7	Start Buttons (Green)	<ul style="list-style-type: none"> • Starts the unit • Press green buttons simultaneously to start
8	Control Buttons	<ul style="list-style-type: none"> • Input buttons (see Fig. 4.0 and Fig. 5.0)
9	Air Regulator	<ul style="list-style-type: none"> • Regulates the air pressure to the unit
10	Emergency Stop button (Red)	<ul style="list-style-type: none"> • Stops the Unit in an Emergency • Press to Engage • “E-Stop!” will be displayed, • To reset, rotate the E-Stop knob a quarter turn clockwise
11	LCD Display	<ul style="list-style-type: none"> • Displays unit status, operation and error messages.
12	Protective (Safety) Cover	<ul style="list-style-type: none"> • Protects operators when machine is in use
13	Plunger Disk	<ul style="list-style-type: none"> • Part of Plunger Assembly
14	Fluid Level Sensor	<ul style="list-style-type: none"> • Senses the fluid level at the top of the cartridge

15	Fluid Level Magnet	<ul style="list-style-type: none"> • Works with fluid level sensor
16	Plunger Assembly	<ul style="list-style-type: none"> • Locks cartridge in place • Applies steady pressure to prevent air entrapment
17	Flow Control; Main Cylinder	<ul style="list-style-type: none"> • Controls the speed of the main cylinder • Rotate the flow control screw clockwise to increase the speed. • Rotate the flow control screw counterclockwise to decrease the speed
18	Flow Control; Injection Rod	<ul style="list-style-type: none"> • Controls the speed of the injection rod • Rotate the flow control screw clockwise to increase the speed. • Rotate the flow control screw counterclockwise to decrease the speed
19	Voltage Select Switch	<ul style="list-style-type: none"> • Select 115V or 230V
20	Power Input Socket with Fuse Box	<ul style="list-style-type: none"> • Input power connection
21	Air Filter	<ul style="list-style-type: none"> • Provides air filtration
22	Wrench	<ul style="list-style-type: none"> • Used to install the air filter assembly and drive spindle assembly
23	Accessories Bracket	<ul style="list-style-type: none"> • To hold wrench or other accessories
24	Cartridge Holder Bracket	<ul style="list-style-type: none"> • To hold extra cartridge holder

8. SETUP AND OPERATION

WARNING: This unit is equipped with a voltage selector switch. Please check to make sure the voltage selector is set to match the voltage input.

8.1 Voltage Selection and Fuse Replacement

1. Select the proper voltage by sliding the voltage switch up or down

Voltage Range	Voltage Setting	Fuse Rating
100V – 120V	115V	2 Amp, Type F
220V – 240V	230V	2 Amp, Type F

Fuse Replacement: The unit is shipped with the fuse installed. If fuse needs to be replaced please follow instructions below

2. Remove the fuse holder by using a flat head screw driver to pry it open.
3. Insert correct fuse into the fuse box, refer to table above
4. Re-install the fuse holder into the unit

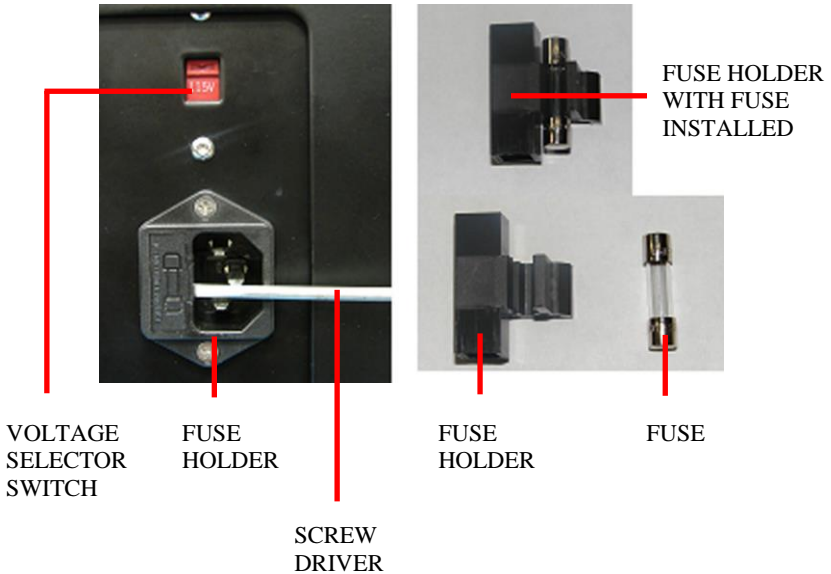

Figure 6.0 Fuse Installation

8.2 Plastic Tray Installation

The unit is shipped with a plastic tray to prevent any spilled material migrating into the main control panel. Make sure to install the plastic tray onto the base plate by aligning the four tabs into the base plate holes.

8.3 Spindle and Spindle Extension Installation

The unit is shipped with the spindle uninstalled. To install the spindle, align it on the motor drive shaft then turn in clockwise direction.

Note: The spindle is designed to mix cartridge kits with 8" (203mm) mix rod. To mix cartridge kits with 6" (152mm) mix rod, the spindle extension needs to be installed. Follow the instructions below to install the spindle extension:

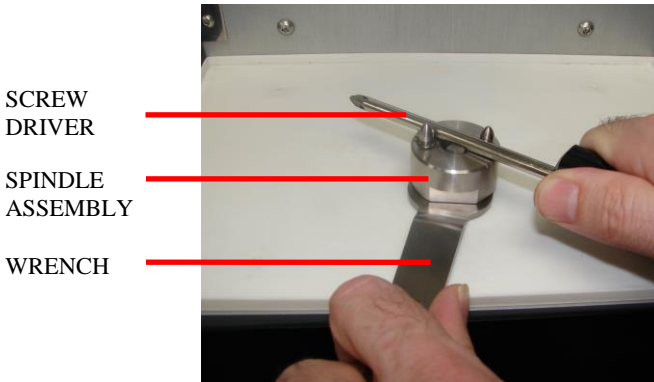

Figure 7.0. Remove Spindle Assembly



Figure 8.0. Spindle Assembly with Extension

1. Place the wrench on the motor shaft (beneath the spindle).
2. Place a screw driver between the two locking pins of the spindle.
3. Hold the wrench and turn the screw driver counter clockwise to unscrew the spindle assembly.
4. Remove the spindle assembly from the motor shaft.
5. Install the spindle extension on the motor shaft by turning it clockwise.
6. Install the spindle assembly on the spindle extension by turning it clockwise.

8.4 Turn On the Unit

Caution: Make sure the correct fuse has been installed and the correct voltage has been set. Refer to section 8.1 for instructions.

1. Insert the power cord to the power socket (Fig. 3, 20).
2. Connect the air filter assembly to the air inlet (Fig. 3, 21).
3. Connect the air hose to the air filter assembly .

Caution: The air filter assembly (7091-9080), supplied with the unit, must be installed to ensure proper air filtration.

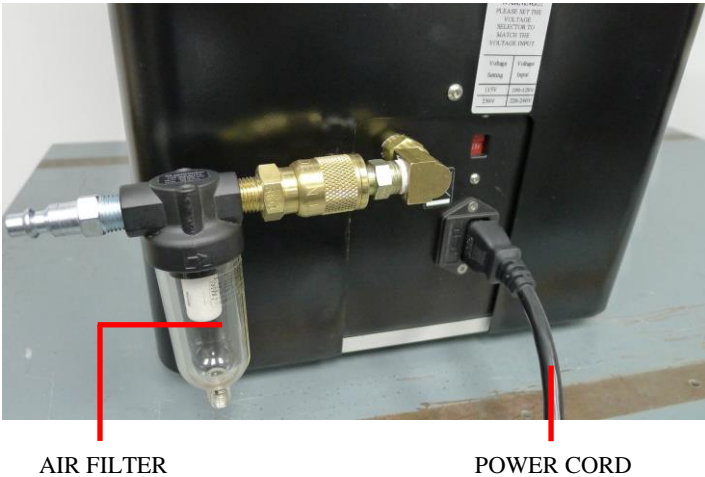

Figure 9.0 Air and Power Connection

4. Set the air Pressure to 80 psi (5.5 bar) minimum.
 - Rotate the air pressure regulator knob (Fig. 2, 9) clockwise to increase the air pressure.
 - Rotate the air pressure regulator knob counterclockwise to decrease the air pressure.

5. The desired air pressure will be displayed on the screen.
6. Turn on the unit by pressing the power button (Fig. 4). The cartridge holder should move up to home position. If it does not move up, please check pressure connection.

8.5 Cartridge Kit Preparation

Injection Kit:

The TS6500 Mixer has an automatic injection device that will inject the hardener into the catalyst before the mixing cycle starts. However, the valve in the mix rod needs to be opened before placing the kit in the machine. Follow the below instructions to open the valve.

1. Insert the ram rod into the mix rod.
2. Push the ram rod to force the valve open.
3. Follow the instructions in section 8.7 to mix the injection kit.

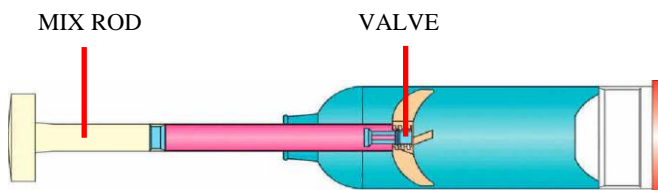

Figure 10.0 Injection Kit

Barrier Kit

1. Remove barrier tape from the kit.
2. Pull the mix rod down to the fullest extent to remove the foil from the dasher.
3. Follow instructions in section 8.7 to mix the barrier kit

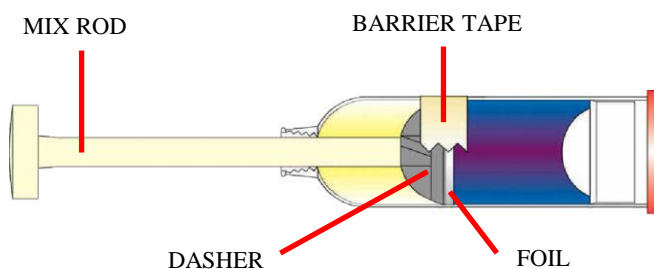

Figure 11.0 Barrier Kit

8.6 Loading the Cartridge Kit

Note: The unit is setup to mix cartridge kit with 8" (203mm) mix rod. To mix cartridge kit with 6" (152mm) mix rod, the spindle extension needs to be installed. Refer to section 8.3 for instructions.

1. Open the safety cover (Fig. 2.0, 12).
2. Load the cartridge kit into the cartridge holder (Fig. 2.0, 2).
3. Pull the mix rod to the fullest extend then align the two through holes of the rod to the drive spindle (Fig. 2.0, 6).
4. Turn the cartridge kit lightly in clockwise direction to lock it to the spindle.
5. Insert the plunger assembly (Fig. 2.0,16) into the cartridge holder with the plunger correctly seated inside the cartridge.
6. Align the dowel pins of the plunger assembly with the bayonet slots in the cartridge holder and turn counterclockwise until it locked in.
7. Connect the air hose into the plunger air inlet (Fig. 2.0, 4).
8. Close the safety cover.

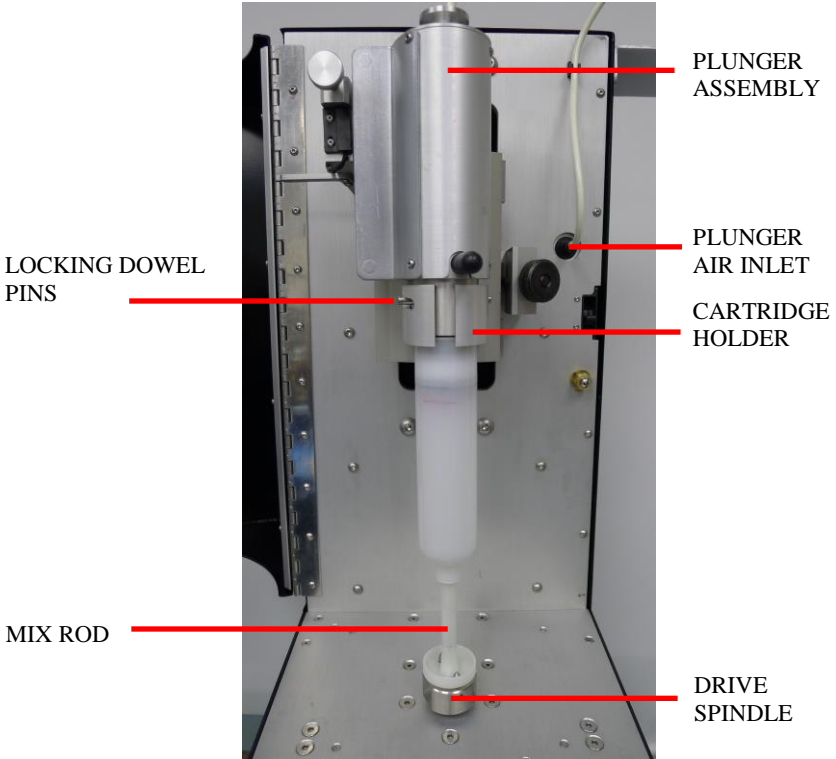

Figure 12.0 Loading the Cartridge Kit

8.7 Mix Cycle Program Setup

Refer to Fig. 4.0.

1. Press the Mode button to select Auto mode.
2. Press and hold the Setup button for 3 seconds to enter setup screen.
3. Press the Setup button to move the cursor to the “CYCLE” indicator.
4. Press the (+) and (-) button to set number of mix cycles required.
5. If a delay time is required, press the Setup button to move the cursor to the “DELAY” indicator then press the (+) and (-) button to adjust delay time, for up stroke and down stroke. (Fig. 5.0 D: Down / U: Up)
6. Press and hold the Setup button for 3 seconds to save data. The unit is now ready to run.

8.8 Start The Unit

1. Ensure the unit is in the Automatic Mode and the desired profile has been selected.
2. Press and release the Start buttons (Green) (Fig 2.0, 7) simultaneously.
3. The unit will run the selected profile. The cycle count and elapsed time will be displayed on the LED screen.

8.9 Unloading The Cartridge Kit

1. The machine will automatically stop once the mixing cycles are completed.
2. Open the protective cover (Fig. 2.0, 12).
3. Remove the retaining collar plunger assembly (Fig. 2.0, 16) by turning it clockwise.
4. Place the retaining collar plunger assembly on the side bracket (Fig. 2.0, 1).
5. Turn the cartridge kit clockwise to remove it from the drive spindle.
6. Pull the cartridge kit out of the cartridge holder.

8.10 Manual Mode

While in the manual mode, the injection rod, main cylinder and drive spindle motor may be controlled independently. Note: while in manual mode any errors will not halt the operation of the motors. Refer to Fig. 13.0.

1. Press and hold the Mode button for 3 seconds to select Manual mode
2. Press the Power (-) button to activate the injection rod (the injection rod will move up).
3. Press the Mode button (+) to activate the motor (the drive spindle will rotate).
4. Press the Setup button (↵) to activate the main cylinder (the cartridge holder will move up and down).

Figure 13.0 Manual Mode Screen

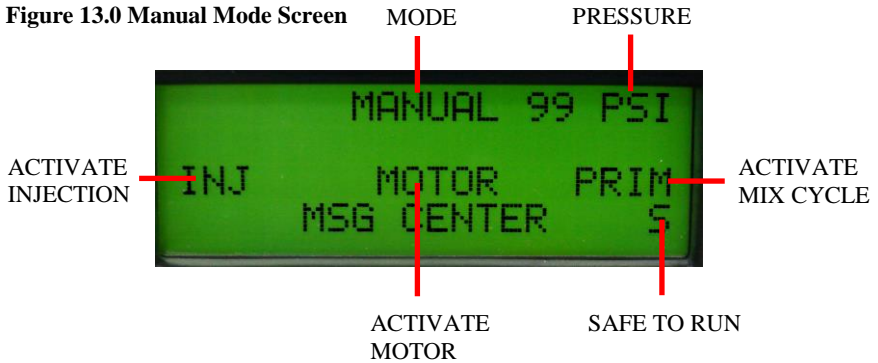

9. SPEED CONTROL

9.1 For main cylinder

The main air cylinder drives cartridge kit up and down. The stroke speed of the main air cylinder can be adjusted by rotating the flow control screw (Fig. 14.0) counter clockwise to increase the speed and clockwise to decrease the speed.

9.2 For injection rod

The injection rod air cylinder drives the injection rod up and down. The injection speed can be adjusted by rotating the flow control screw (Fig. 14.0) counterclockwise to increase the speed and clockwise to decrease the speed.

Note: For TS6500CIM-SMR-6 and TS6500CIM-SMR-20 models, the injection rod flow control is shut-off from the factory. To re-activate the injection rod, slowly turn the flow control screw counter-clockwise until the desired speed is achieved.

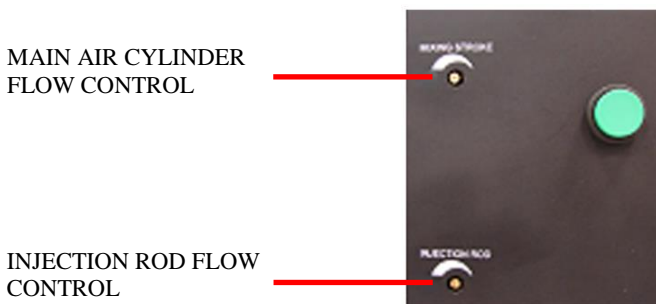

Figure 14.0 Flow Control

10. TROUBLESHOOTING

PROBLEM	POSSIBLE CAUSE	CORRECTION
Unit fails to start	<ul style="list-style-type: none"> No power input Emergency button is pressed Safety door is not fully closed 	<ul style="list-style-type: none"> Check power connections Release Emergency stop button Close safety door
LCD does not light	<ul style="list-style-type: none"> No power input 	<ul style="list-style-type: none"> Check power connections Check Fuse Turn on power
Air Cylinder does not move	<ul style="list-style-type: none"> Insufficient air pressure Air hoses not plugged in Regulator defective 	<ul style="list-style-type: none"> Increase air pressure to 80 psi (5.5 bar) Check air connection Replace regulator
The hardener is not completely injected	<ul style="list-style-type: none"> Air cylinder is damaged 	<ul style="list-style-type: none"> Replace air cylinder
The injection rod does not retract	<ul style="list-style-type: none"> Injection rod is dirty Injection rod is bent 	<ul style="list-style-type: none"> Clean rod Replace rod
Material is not completely mixed	<ul style="list-style-type: none"> Not enough mixing cycle Insufficient air pressure 	<ul style="list-style-type: none"> Increase number of cycles Increase air pressure to 80 psi
Cartridge holder is not in "Home" position	<ul style="list-style-type: none"> Insufficient air pressure Air hoses not plugged in 	<ul style="list-style-type: none"> Increase supply pressure to 80 psi (5.5 bar) Check air connection
Mixing rod does not reach spindle	<ul style="list-style-type: none"> Extension spindle is not installed for 6" rod Mixing rod in not fully extended 	<ul style="list-style-type: none"> Install extension spindle for 6" rod Extend mixing rod
No pressure on plunger	<ul style="list-style-type: none"> Plunger air hose is not connected 	<ul style="list-style-type: none"> Connect plunger air hose
Plunger disk does not fit inside cartridge	<ul style="list-style-type: none"> Wrong plunger disk size 	<ul style="list-style-type: none"> Use correct plunger disk size
Cartridge holder remains in the down position during mixing cycle	<ul style="list-style-type: none"> Sensor and magnet is not aligned 	<ul style="list-style-type: none"> Turn off unit and adjust sensor / magnet alignment
Motor is not running	<ul style="list-style-type: none"> No power to motor Motor burned out 	<ul style="list-style-type: none"> Check motor connection Replace motor

11. PROGRAM SELECTION

Up to 10 programs can be stored in the the TS6500 Mixer.

1. Press the Set button (Fig. 4.0) to highlight the program number selection.
2. Press the (+) or (-) buttons to select desired program.
3. Press the Set button to exit.

12. CYCLE COUNTER RESET

The cycle counter can record up to 99999 mix cycles. To reset the cycle counter follow the below instructions:

1. Press and hold Setup button for 3 seconds to enter setup mode.
2. Once the setup mode is displayed, press and hold Setup button again until the cycle counter resets to “00000”.

13. CARTRIDGE HOLDER INSTALLATION

Refer to Fig. 15.0 and 16.0

The TS6500CIM-6 is setup to mix the 6.0oz. (160ml) kit. To mix the 2.5oz (60ml) or 8.0oz. (220ml) kit the cartridge holder needs to be re-installed at the correct mounting locations as shown in Fig. 15.

MOUNTING LOCATION
2.5oz (60ml) KIT

MOUNTING LOCATION
6.0oz (160ml) KIT

MOUNTING LOCATION
8.0oz (220ml) KIT

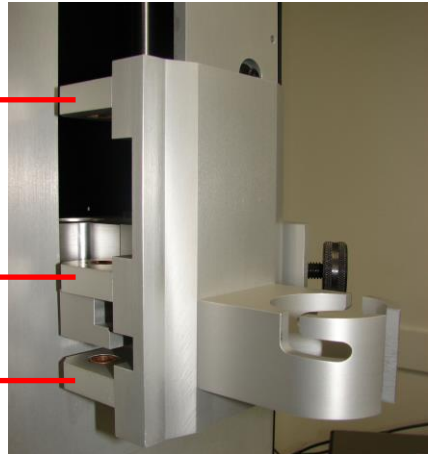

Figure 15.0 Mounting Location

The cartridge holder can be installed in a few simple steps:

1. Pull the release knob and push the fluid level sensor assembly to the left.
2. Loosen the locking screw by turning it counter clockwise.
3. Rotate the cartridge holder outward and pull it up to remove from the machine.
4. Install new cartridge holder in the reverse order.
5. Pull release knob to rotate fluid level sensor assembly back into position.

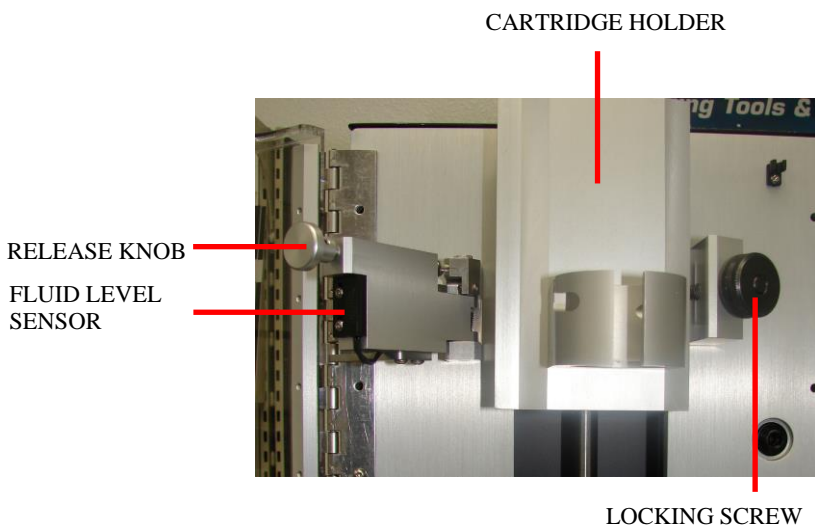

Figure 16.0 Cartridge Holder

14. MAINTENANCE

The TS6500 Mixer is designed and built to be relatively maintenance free. To assure trouble free operation, the following recommendations should be followed:

1. Make certain the air supply is clean and dry.
2. Avoid connecting the unit to excessive moisture or solvent saturation.
3. Use only Amyl Alcohol to clean outside surface of the main housing.
4. Use only soft cloth to clean the LCD.
5. Clean the injection rod regularly with cleaning solvent
6. Clean the tray regularly with cleaning solvent

15. LIMITED WARRANTY

OK International warrants this product to the original purchaser for a period of one (1) year from date of purchase to be free from material and workmanship defects but not normal wear-and-tear, abuse and faulty installation. Defective product or subassembly and components under warranty will be repaired or replaced (at OK International's option) free of charge. Customer with defective product under warranty must contact the nearest OK International office or distributor to secure a return authorization prior to shipping the product to the assigned OK International authorized service center. For nearest OK International office or distributor contact information, please visit www.okinternational.com. OK International reserves the right to make engineering product changes without notice.

16. APPENDIX 16.1 - Spare Parts List

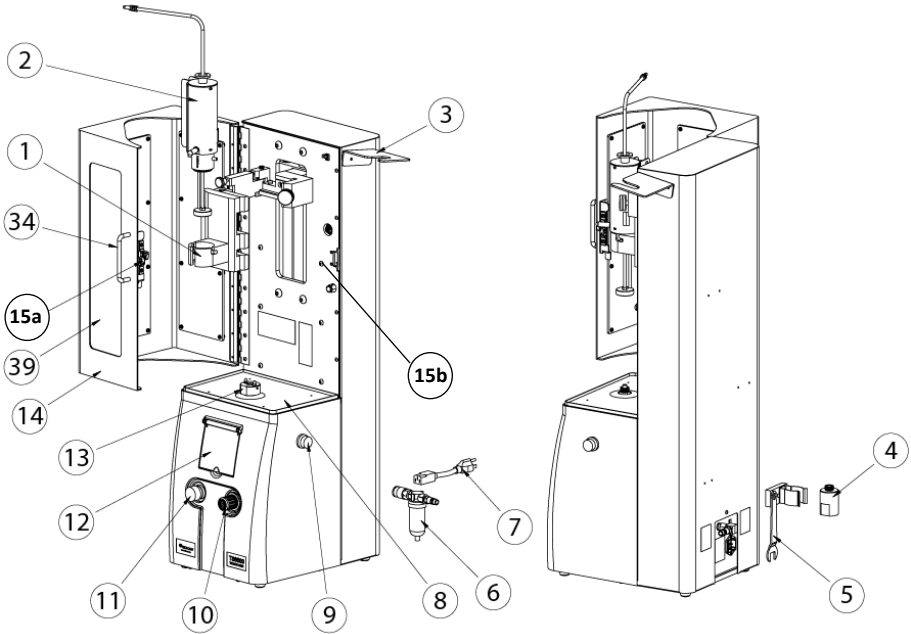

Figure 17.0 Main Assembly

ITEM	PART NUMBER	DESCRIPTION	QTY
1	7091-9010	CARTRIDGE HOLDER, 2.5oz/6oz/8oz	1
	7091-9030	CARTRIDGE HOLDER, 20 oz	1
2	7091-9040	PLUNGER ASSEMBLY, 2.5oz/6oz/8oz	1
	7091-9060	PLUNGER ASSEMBLY, 20 oz	1
3	7091-0740	HOLDER, PLUNGER ASSEMBLY	1
4	7091-0120	SPINDLE EXTENSION	1
5	7091-0530	WRENCH, THIN HEAD, 19mm	1
6	7091-9080	AIR FILTER ASSY (Filter only = 2700-0048)	1
7	6002-0703	POWER CORD	1
8	7091-0500	TRAY	1
9	5100-0079	START PUSH BUTTON	2
10	TSD500-29	AIR REGULATOR	1
11	5100-0078	E-STOP SWITCH	1
12	7091-0510	LCD COVER	1
13	7091-9180	SPINDLE ASSEMBLY	1
14	7091-0430	SAFETY DOOR	1
15a	5100-0077	SAFETY DOOR LATCH	1
15b	5100-0109	SAFETY SWITCH	1

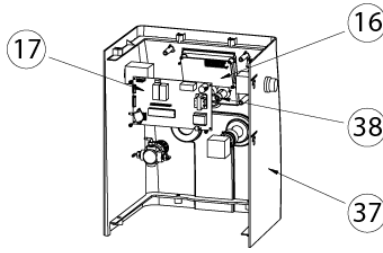

Figure 18.0 Inside Front Cover Assembly

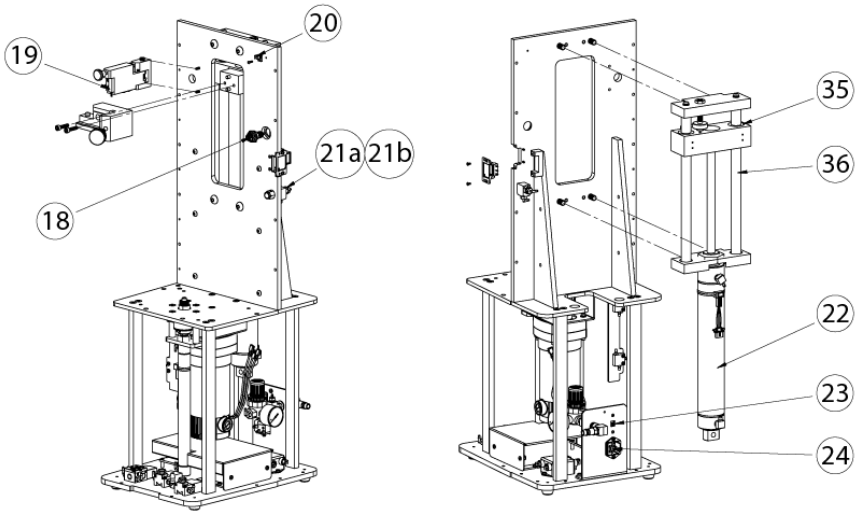

Figure 19.0 Inside Assembly Level One

ITEM	PART NUMBER	DESCRIPTION	QTY
16	2900-0015	LCD	1
17	7091-9000	PCBA, TECHKIT MIXER	1
18	535	PLUNGER AIR INLET	1
19	5500-0008	FLUID LEVEL SENSOR	1
20	3300-0408	TUBE HOLDER, 1/4" TUBE DIA.	1
21a	2600-0162	PRESSURE RELIEF VALVE STEM	1
21b	2600-0163	PRESSURE RELIEF VALVE ACTUATOR	1
22	7091-9140	MAIN AIR CYLINDER	1
23	5100-0060	VOLTAGE SELECT SWITCH	1
24	2100-0372	POWER CONNECTOR	1

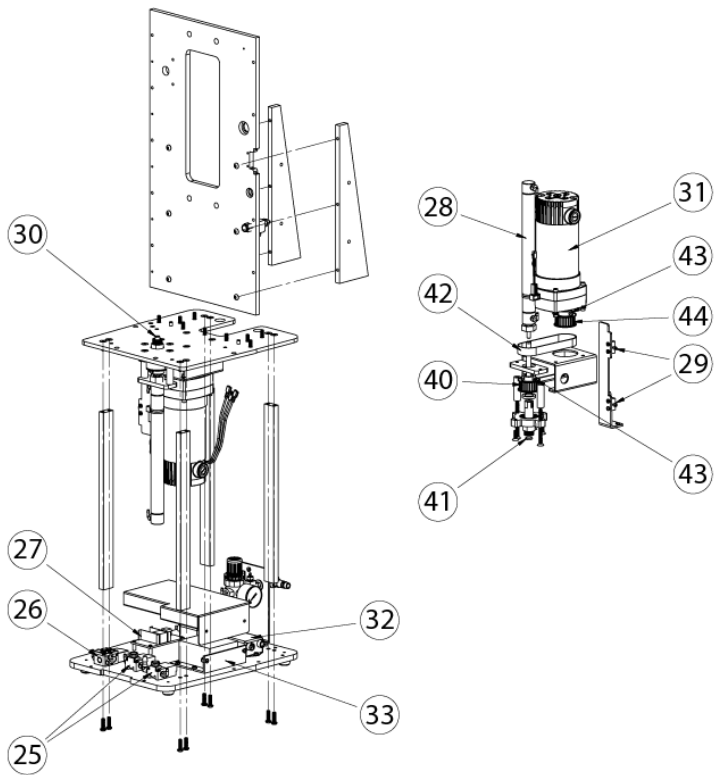

Figure 20.0 Inside Assembly Level 2

ITEM	PART NUMBER	DESCRIPTION	QTY
25	TSD650-21	SOLENOID VALVE	2
26	2600-0132	SOLENOID VALVE, 4-WAY	1
27	1700-0027	DC POWER SUPPLY	1
28	7091-9150	AIR CYLINER, INJECTION ROD	1
29	TSD210-6	FLOW CONTROL	2
30	7091-9130	SPINDLE SHAFT ASSY /BEARING SLEEVE	1
31	7091-9160	MOTOR ASSEMBLY	1
32	2700-0046	FILTER, EMI, 115/250 VAC, 3A, 50-60 Hz	2
33	7091-9120	MOTOR DRIVER	1

ITEM	PART NUMBER	DESCRIPTION	QTY
34	3300-0409	HANDLE, M4 X 96MM LG, BLACK ANODIZE	1
35	3300-0465	BUSING LINEAR,.75 IDX1.250DX1.63 LG, FRELON-LINED	2
36	7091-0210	GUIDE SHAFT	2
37	7091-0450	COVER, BASE	1
38	7091-0540	BUTTON PAD	1
39	7091-0670	PANEL ACRYLIC	3
40	7091-0850	TIMING PULLEY MODIFIED, SPINDLE SHAFT	1
41	3300-0403	O-RING, 8.3MM ID X 13.1MM OD X 2.4MM CS., BUNA-N	1
42	3300-0557	TIMING BELT, TS6500	1
43	2800-0838	SCREW, SET, M4 X 5MM, EXT. POINT, STEEL, BLK.	2
44	7091-0840	TIMING PULLEY MODIFIED, MOTOR SHAFT	3

16.2 TECHKIT PART NUMBER CHART

SIZE	PART NUMBER	ROD LENGTH	KIT TYPE
2.5 oz. (60ml)	250-61T	6" (152mm)	Taped Barrier
	250-81T	8" (203mm)	Taped Barrier
	250-60	6" (152mm)	Injection
	250-80	8" (203mm)	Injection
6.0 oz. (160ml)	600-61T	6" (152mm)	Taped Barrier
	600-81T	8" (203mm)	Taped Barrier
	600-60	6" (152mm)	Injection
	600-80	8" (203mm)	Injection
8.0 oz. (220ml)	800-61T	6" (152mm)	Taped Barrier
	800-81T	8" (203mm)	Taped Barrier
	800-60	6" (152mm)	Injection
	800-80	8" (203mm)	Injection
20 oz. (550ml)	200-81T	8" (203mm)	Taped Barrier
	200-80	8" (203mm)	Injection
1/10 gal (310ml)	110-81T	8" (203mm)	Taped Barrier
	110-80	8" (203mm)	Injection



Adhesive Dispensing Ltd
14 Clarke Road, Mount Farm
Milton Keynes, Bucks, MK1 1LG, UK
Tel. +44 (0) 1908 686660
Fax: +44 (0) 1908 686836